



## W-FR3 Floatless Relay Code : 5200



### FLOATLESS LEVEL CONTROLLER Automatic Water Supply and Drainage Control

- AC operating voltage
- Ideal for level control of any conductive liquid
- The circuits are designed to protect against the surge
- The performance condition is shown by LED indicator
- The W-FR3 floatless relay is compact plug-in type
- Fits standard 8-pin sockets

### Operation

LED	Pump	Tank
Green	Run	Water flow
Red	Stop	Full

### Specification

#### Feature

Input voltage	: 220 and 380 VAC
System frequency	: 50/60 Hz.
Power consumption	: 2VA
Working resistance	: 600 K ohm or more
Electrode circuit voltage	: AC 9V
Insulation resistance	: 10M ohm or more
Max. cable length	: 700 M. (0.75 mm. 600 V 3E Cabtype cable)

#### Relay output

Output type	: SPDT
Contact rating	: 5A at 250 VAC
Operations	: Mechanical : $2 \times 10^7$ times
	: Electrical : $1 \times 10^5$ times

#### Environmental

Operating temperature	: $-10^{\circ}$ to $+55^{\circ}$ C
Storage temperature	: $-10^{\circ}$ to $+70^{\circ}$ C
Ambient humidity	: Max 85%RH

#### Enclosure

Mounting	: Plug-In socket
Housing	: ABS plastic
Wire fixing	: 8 Pin socket base-round
Indicator	: LED 3 mm
Dimension (mm)	: 39 x 49 x 72
Weight	: 130 g

### Diagram

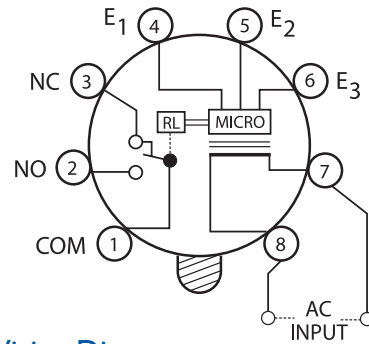

### External Wiring Diagram

#### WATER SUPPLY

When liquid in the tank is dropped to the level below E2 (medium), the motor will be turned on. When the level rises to E1 (high) it will be turned off.

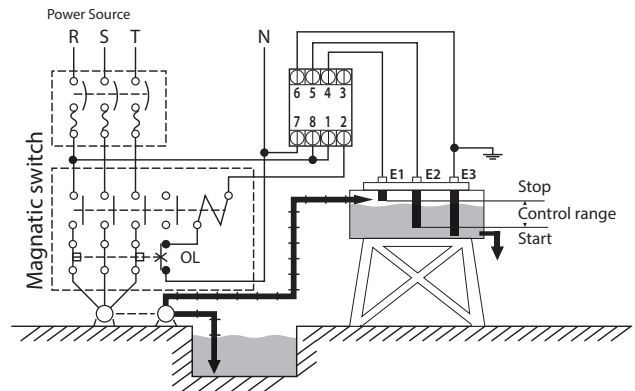

#### DRAINAGE

When the liquid level in the tank exceeds E1 (high), the motor will be turned on. When the level drops to E2 (medium) it will be turn off.

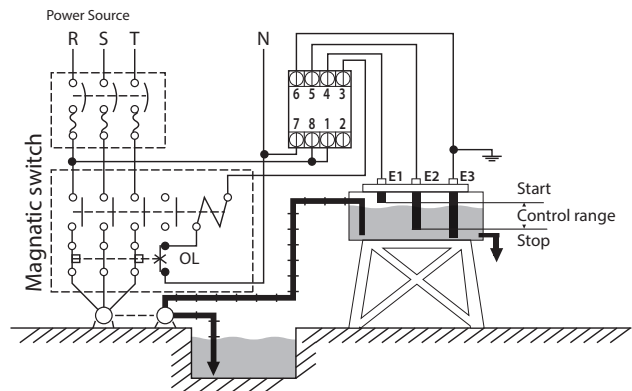

### Dimension in mm.

